

Pleasure Series

Air Cooler SOLO45



Customer Values

- Expanded commercial chiller cooling capacity to meet more applications
- High heat transfer efficiency, energy saving and highly efficient
- Efficient defrosting, saving operating costs, low temperature fluctuations, ensuring the safety and freshness of goods
- Sheet metal parts have long service life, validated by long-term corrosion resistance tests
- Simple structure, easy to install and maintain

Product Features

- 450mm-diameter fan of 24 models, cooling capacity: 5.7~ 41 kW
- 1~4 fans, suitable for SC2 and SC3 working conditions, and multiple applications
- Suitable for medium-sized logistics cold rooms, supermarket distribution warehouses, forecourt cold rooms, etc. with -18 °C ~ +0 °C storage temperatures
- Optional electric defrost/air defrost
- Highly efficient copper tube fins - corrugated fins - to increase evaporative surface area and heat transfer efficiency
- Perfect surface spraying process - powder coating that meets the higher hygiene standard (HACCP), anti-corrosion and anti-rust, longer service life, easy to clean and maintain

Naming Rule of Air Cooler

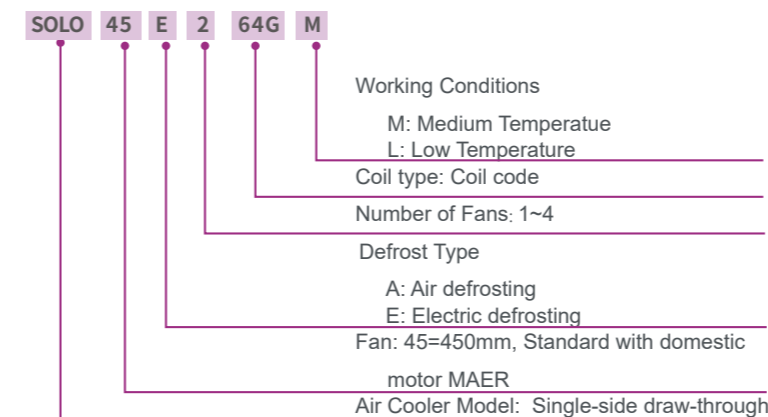

Non-standard Option

Item	Standard Parts	Non-standard Parts	Description
1	Aluminium foil	Coil protective coating (Epoxy coating, Hydrophilic aluminum foil, etc)	Epoxy coating: for corrosive applications Hydrophilic aluminum foil: used in high humidity, easy to frost occasions
2	MAER Motor	EBM Motor	High-end motor brand
3	MT: 4.5mm LT: 7.0mm	Max Fin Distance: 12mm	Reduce fin frosting and ensure heat transfer performance
4	N/A	Wind ring heating tape	Used for harsh application, to avoid wind circle frost caused by abnormal fan
5	Galvanized sheet spraying	Stainless steel case	Food grade application, more corrosion resistant
6	Electric defrosting	Hot gas defrosting	Energy saving by using compressor waste heat to defrost
7	Drain pan	Dual-layer drain pan	Avoid condensation dripping from the catch basin due to hot and cold convection

Neutral Salt Spray Test of Coil Coating

Type of anticorrosive coating	Neutral salt spray test (H)
Hydrophilic aluminum foil	500
Epoxy coating	>1500

Performance Parameters (SOLO 45)

Type: SOLO	Model SOLO				Cooling Capacity R404A				Connection				Fan			Electric Defrosting 230V -1			Weight			
	Fan Dimension (cm)	Number of Motors	Coil Rows	Fin Distance	Coil Code	SC2		SC3		Inlet Dimension	Outlet Dimension	Input Power	Input Current	Power Supply	External Dimension	Coil	Water Pan	Total				
						Heat Transfer Temperature Difference 8K	Evaporating Temperature -8°C	Heat Transfer Temperature Difference 7K	Evaporating Temperature -25°C											50 Hz	W	A
SOLO	45	1	4	4	G	7.6	/	5.7	31.1	5450	27	62	5/8"	1 3/8"	400	1.82	230V-1	1194*630*674	3.3	1.1	4.4	64
SOLO	45	1	6	4	G	9.2	/	8.5	46.6	5200	25	62	5/8"	1 3/8"	408	1.86	230V-1	1194*630*674	4.4	1.1	5.5	75
SOLO	45	1	4	7	G	/	5.1	5.7	20.7	5600	31	62	5/8"	1 3/8"	396	1.80	230V-1	1194*630*674	3.3	1.1	4.4	64
SOLO	45	1	6	7	G	/	6.7	8.5	31.1	5500	29	62	5/8"	1 3/8"	400	1.82	230V-1	1194*630*674	4.4	1.1	5.5	74
SOLO	45	2	4	4	G	15.5	/	11.6	63.3	11000	31	65	5/8"	1 5/8"	800	3.64	230V-1	2076*630*674	6	1.6	7.6	110
SOLO	45	2	6	4	G	20.1	/	17.3	94.9	10500	29	65	7/8"	1 5/8"	816	3.72	230V-1	2076*630*674	8	1.6	9.6	130
SOLO	45	2	4	7	G	/	10.4	11.6	42.2	11400	35	65	5/8"	1 5/8"	792	3.60	230V-1	2076*630*674	6	1.6	7.6	109
SOLO	45	2	6	7	G	/	13.7	17.3	63.3	11000	33	65	5/8"	2 1/8"	800	3.64	230V-1	2076*630*674	8	1.6	9.6	128
SOLO	45	3	4	4	G	23.6	/	17.4	95.5	16500	35	67	7/8"	2 1/8"	1200	5.46	230V-1	2958*630*674	9.2	2.3	11.5	155
SOLO	45	3	6	4	G	30.8	/	26.2	143.3	15700	33	67	7/8"	2 1/8"	1224	5.58	230V-1	2958*630*674	11.5	2.3	13.8	186
SOLO	45	3	4	7	G	/	15.7	17.4	63.7	17000	39	67	7/8"	2 1/8"	1188	5.40	230V-1	2958*630*674	9.2	2.3	11.5	154
SOLO	45	3	6	7	G	/	20.5	26.2	95.6	16500	37	67	7/8"	2 1/8"	1200	5.46	230V-1	2958*630*674	11.5	2.3	13.8	184
SOLO	45	4	4	4	G	33.9	/	29.2	159.7	21800	38	68	1 1/8"	2 1/8"	1600	7.28	230V-1	3840*630*674	12.5	3.3	15.8	222
SOLO	45	4	6	4	G	41	/	35.0	191.7	21000	36	68	1 1/8"	2 5/8"	1632	7.44	230V-1	3840*630*674	15	3.3	18.3	240
SOLO	45	4	4	7	G	/	23.4	29.2	106.6	22400	42	68	1 1/8"	2 5/8"	1584	7.20	230V-1	3840*630*674	12.5	3.3	15.8	221
SOLO	45	4	6	7	G	/	27.2	35.0	127.9	22000	40	68	1 1/8"	2 5/8"	1600	7.28	230V-1	3840*630*674	15	3.3	18.3	238