

SCU Ivian Series

Crown Case Service Counter



Technical Data

Series	Standard Model	Dimensions (LxWxH)	Operating Temperature (°C)	Net Volume/m ³	Display Area/m ²	Net Weight / kg
Crown Case Service Counter	SCU 207 75 R S CE	2070*1035*870	-1~5	0.240	1.48	255
	SCU 125 75 R S RC	1250*2070*870	-1~5	0.296	1.80	310
	SCU 188 75 R S RC	1875*2070*870	-1~5	0.442	2.70	460
	SCU 250 75 R S RC	2500*2070*870	-1~5	0.590	3.60	600

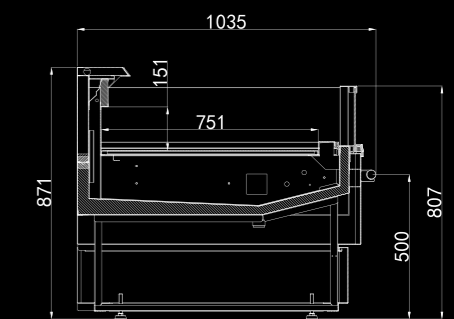

Product Features

- ☒ The run case is equipped with double-valve and double-control technology for more stable operation
- ☒ The standard remote controller is placed on the deck, convenient for customers to read temperatures and adjust parameters
- ☒ Double-sided counter with an integrated deck for an elegant appearance

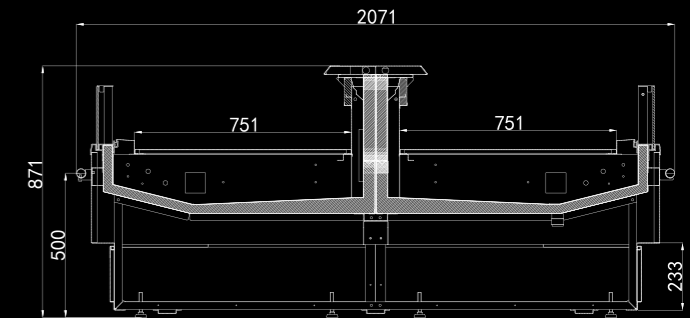

* All comparisons are based on the product performances of last generation.