

SCU Ivian Series

Double Shelf Service Counter



Technical Data

Series	Standard Model	Dimensions (LxWxH)	Operating Temperature (° C)	Net Volume/ m ³	Display Area/m ²	Net Weight / kg
Double Shelf Service Counter	SCU 063 75 R S DS	625*1055*1050	-1~5	0.100	0.49	95
	SCU 094 75 R S DS	937*1055*1050	-1~5	0.150	0.74	125
	SCU 125 75 R S DS	1250*1055*1050	-1~5	0.200	0.98	170
	SCU 188 75 R S DS	1875*1055*1050	-1~5	0.300	1.47	255
	SCU 250 75 R S DS	2500*1055*1050	-1~5	0.410	1.97	340
	SCU 375 75 R S DS	3750*1055*1050	-1~5	0.610	2.95	510
	SCU EC90 75 R S DS	1650*1650*1050	3~8	0.260	1.28	350
	SCU IC45 75 R S DS	1232*1171*1050	3~8	0.130	0.68	160
SCU EC45 75 R S DS	1230*1172*1050	3~8	0.125	0.66	170	

Product Features

- ☒ Large depth in the front of the service counter, with a depth of 218mm
- ☒ Integrated energy saving lights and overnight blinds as standard
- ☒ The standard remote controller is placed on the deck, convenient for customers to read temperatures and adjust parameters

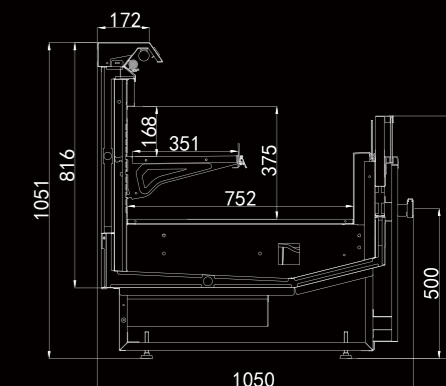

* All comparisons are based on the product performances of last generation.