

SCU Ivian Series



Technical Data

Series	Standard Model	Dimensions (LxWxH)	Operating Temperature (° C)	Net Volume/ m ³	Display Area/m ²	Net Weight / kg
Service Over Counter with Sliding Doors	SCU 063 75 R T	625*1055*1165	-1~5	0.070	0.40	95
	SCU 094 75 R T	937*1055*1165	-1~5	0.110	0.61	125
	SCU 125 75 R T	1250*1055*1165	-1~5	0.148	0.81	170
	SCU 188 75 R T	1875*1055*1165	-1~5	0.221	1.22	255
	SCU 250 75 R T	2500*1055*1165	-1~5	0.295	1.62	340
	SCU 375 75 R T	3750*1055*1165	-1~5	0.443	2.43	510
	SCU EC90 75 R T	1650*1650*1165	3~8	0.195	1.27	350

Product Features

- ☑ Straight front panel cover, simple and premium, convenient for customers' renovation
- ☑ Crash bar options: stainless steel or aluminum alloy
- ☑ Front glass and return air glass are effectively stitched together
- ☑ The large size of the exterior corner counter is convenient for various layouts and form a perfect "S" shape with interior corner counters

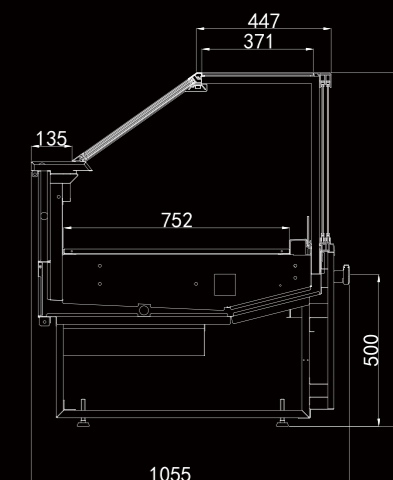

* All comparisons are based on the product performances of last generation.